

VS SERIES MOTORIZED ON/OFF VALVE

PRODUCT SPECIFICATION SHEET



Application

The VS series valves with spring return function are used in HVAC system to control the flow of hot and/or cold water, treated water (Max.50% Glycol Solutions) applications are also permissible.

VS valve is one type of control valve that can do on/off control refer to customer's demands. The actuator has the special function that if the power is off, the valve will return to original position by spring. This is a safe and energy saving function to customers.

In addition, this valve is capable of handling greater differential pressures without water-hammer.

Recommended thermostat including T6818, T6800, T6820 and T6861 series

Note:

This series products are not fit for dissolved oxygen application.

Dimensions (mm)

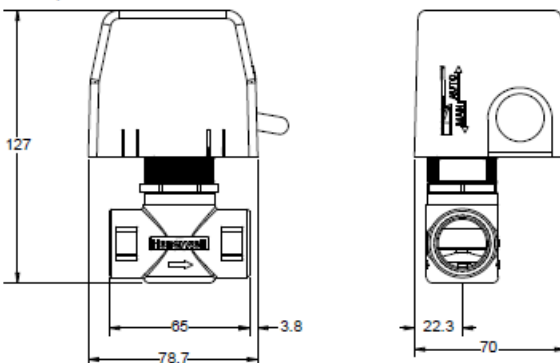

Specifications

Operating Ambient Temperature:

0°C~50°C (32°F ~122°F)

Shipping & Storage Temperature:

-40°C~65°C (-40°F~149°F)

Humidity: 0~90%R.H.

Actuator

Control Type: On/Off

Voltage: 220Vac (±10%) 50/60Hz

Power Consumption: 6.5W

Nominal Timing: Opens in 25 seconds
Close in 6 seconds

Noise: <45dB

Electrical termination: #22AWG

Valve

Medium: Water or water-glycol mixture (max 50% glycol content)

Min.& Max. Fluid Temperature:

1°C~95°C (34°F~203°F)

Static Pressure: 16Bar

Operating pressure differential: Max.3.45Bar

Leakage rate: No visible leakage

Materials:

Valve Body: Forged Brass

Stem: Stainless steel

O ring: EPDM/HNBR

ORDERING

OS#	2/3 Way	Size (in.)	Connection Type	Kv Value
VS4016AB1000T	2	1/2"	BSPT(int)	2.4
VS4016AF1000T	2	1/2"	BSPP(int)	2.4
VS4016AK1000T	2	3/4"	BSPT(int)	3.7
VS4016AJ1000T	2	3/4"	BSPP(int)	3.7
VS4016ZZ11T	Actuator, 220V, 50/60Hz			

Note: All thread connection are internal thread connection

PRESSURE LOSS CHARACTERISTIC

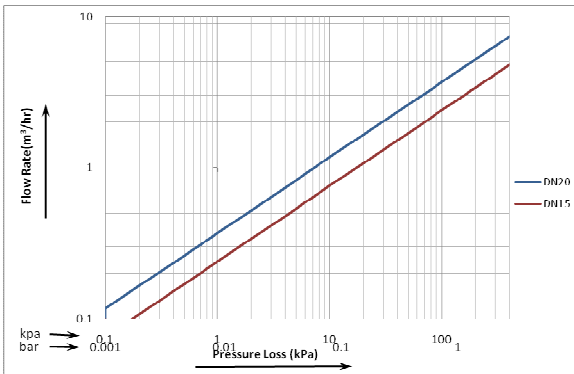

TO INSTALL/ REPLACE ACTUATOR

Caution: Installing a new actuator does not require draining the system, ensure the valve body and valve cartridge assembly properly installed in the pipeline.

1. Check product number and voltage ratings for match with application.
2. Disconnect power supply before servicing to avoid electrical shock or equipment damage.
3. Disconnect lead wires to actuator. Where appropriate, label wires for rewiring.(for replace actuator)
4. The actuator head is threaded to the valve as arrow ①. To install, turn the actuator as arrow ②. To remove, turn the actuator as arrow ③.

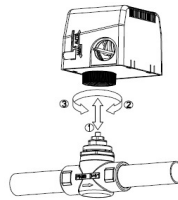

Manual opener

The manual opener can be manipulated only when in the up position. The inlet port can be manually opened by firmly pushing the manual lever down to the lever holder groove. This "manual open" position may be used for filling, venting and draining the system, or for opening the valve in case of power failure. The valve can be restored to the closed position by pushing the manual lever out of the lever holder groove lightly, then the inlet port closed by the spring. it will return to "Auto" position when power is restored.

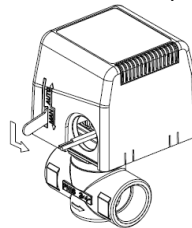

INSTALLATION

WHEN INSTALLING THIS PRODUCT:

1. Read these instructions carefully. Failure to follow them could damage the product or cause a hazardous condition.
2. Check the ratings given in the instructions and on the product to make sure the product is suitable for your application.
3. Installer must be a trained, experienced service-person.
4. Always conduct a thorough check-out when installation is completed.
5. Enough head clearance is required to remove the actuator (at least 90mm above).

CAUTION



1. Disconnect power supply before connecting wiring to prevent electrical shock and equipment damage.
2. Never jumper the supply wires or actuator terminals.

PLUMBING

The valve may be plumbed in any angle but preferably not with the actuator below horizontal level of the body. Make sure there is enough room around the actuator for servicing or replacement (90mm space needed). Mount the valve directly in the tube or pipe.

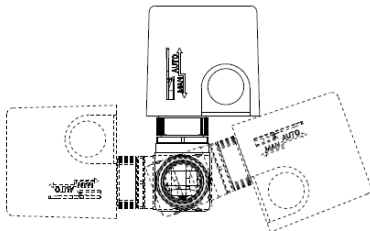

WIRING

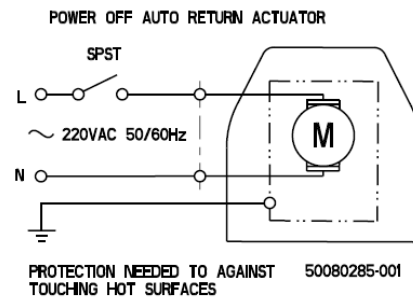

Honeywell

Honeywell Environmental & Combustion Controls (Tianjin) Co., Ltd

No. 158, Nan Hai Road
 Tianjin Economic-Technological Development Area
 Tianjin, 300457, P.R.C.
 Phone: +86-22-6628 7000
 Fax: +86-22-2532 5214
 Subject to change without notice